



FERNE

have a seat.

**FERNE**

have a seat.

# A new brand based on over 30 years of experience.

We believe that everyone deserves to be surrounded by beauty and comfort. That's why we have created FERNE: a fresh new brand of outdoor and indoor furniture, manufactured in Poland, in the very heart of Europe. FERNE is a response to the growing market demand for outdoor and indoor furniture that is both comfortable and aesthetic. The new brand is based on more than 30 years of experience of Prosperplast. It comprises high-quality products that are at the same time comfortable and beautiful. Our furniture is produced in Poland, in Central Europe. It will fit gardens and homes as well as commercial spaces, such as offices, cafes, and hotels.

FERNE is our latest brand. Prosperplast is a family company that specialises in innovative technologies of plastics processing. We are a worldwide organisation with local production plants located in small towns in Southern Poland. Our products are sold in more than 90 countries.

Over the years, we have focused on three key manufacturing processes: injection moulding, blow moulding, and rotational moulding. Each of them is a different method of plastic forming, which gives us and our customers a wide array of new uses and applications. The three decades of business operations have allowed us to acquire ample experience and unique know-how. Our team of experts and modern machinery guarantee the top quality of Prosperplast products. We can also rely on the extensive infrastructure. We have our own transport fleet as well as warehouse space and production halls of more than 200 thousand square metres, located in Poland, Germany, Czechia, and Hungary. Thanks to that, we successfully carry out our projects and deliver novel solutions that meet the needs of our customers.

Since 1993, we have designed and produced numerous creative solutions for homes and gardens: flower pots, rainwater tanks, garden tools, tool boxes, and storage systems. Now it's time for furniture.



We cordially invite you to the FERNE showroom at our headquarters in Rybarzowice, southern Poland.  
In the photo: BRENE collection.  
See more on page 10.



We design furniture with the user's maximum comfort in mind. In the photo:  
Design process of BRENE collection.  
See more on page 10.

## Comfort-focused design.

Comfort is our top priority. When creating the FERNE brand, we have followed the latest global design trends to make our furniture timeless. Drawing from our in-depth knowledge of materials and their distinctive properties, such as elasticity, lightness, and resistance to damage, we create furniture that is not only comfortable for everyday use but also easy to transport and store.

Every piece by FERNE is designed with the users' maximum comfort in mind. We achieve that comfort without using any additional upholstered elements. Thanks to the use of 100% recyclable plastics, our products are an eco-friendly alternative to valuable primary raw materials, such as wood or rattan.

## Quality widely available.

We are deeply convinced that furniture of the best quality should be available to anyone who values beauty and comfort. At FERNE, our goal is to offer first-rate products at affordable prices. To achieve that, we cooperate with renowned design studios from Poland and other countries.

As Prosperplast, based on our 30 years of experience, we have used the existing distribution channels, advanced logistics, and efficient manufacturing processes to turn our vision into reality. What matters to us as well is building long-lasting and committed relationships with our business partners. As we are in constant dialogue with our customers to make sure we understand their needs, we deliver timely and reliable solutions that meet their expectations.

## The circular nature of plastics.

Circularity is one of the key standards at Prosperplast, alongside quality and safety. Our priority objective is to effectively manage resources in line with our philosophy of sustainable development.

Currently, recycled materials from external sources constitute around 40% of all the materials used in our manufacturing plants. We are constantly increasing the use of the recycle thanks to the rapid growth of the plastic recycling sector in Europe.

The furniture by FERNE is characterised by its durability, lightness, and 100% recyclability.

As a large manufacturer, we build internal closed loops of resources, water, and energy. The closed-loop production process reduces the use of industrial water and heat. What's more, we have our own photovoltaic power plant to reduce our carbon footprint even further. In 2023, thanks to our resource management strategies, only 0.5% of our plastic waste had to be recycled externally.



# Rooted in local furniture heritage.

Hardworking, professional, and innovative — the people who live in our region have always been like this. That's why FERNE draws on the rich local furniture tradition that dates back to the 19th century. It was then that bentwood furniture manufacturing developed in the city of Bielsko-Biala and in the region, following the methods by Michael Thonet. As an outstanding entrepreneur with a pioneer spirit, he launched the production of beautiful and functional beechwood furniture, accessible to the general public.

In the 1920s and 1930s, our region was also a leading manufacturing centre of nickel-plated bent tubes furniture. It was from here that Bauhaus icons, created by excellent designers such as Bruno Weil and Marcel Breuer, were sent out into the entire world.

Building on the legacy of Michael Thonet, we have written a new chapter of the local history of furniture manufacturing. At Prosperplast, we produce affordable, durable, and lightweight furniture with a timeless design aesthetic, at the same time taking up new challenges and using innovative plastics processing technologies. Our products are environment-friendly and fully recyclable.

## Brene collection

---



**Chair**

p. 16 / p. 54



**Chair with armrests**

p. 16 / p. 54



**Armchair**

p. 16 / p. 54



**Side table**

p. 18 / p. 55



**Coffee table**

p. 18 / p. 55



**Dining table**

p. 18 / p. 55

## Rimo collection

---



**Chair**

p. 27 / p. 56



**Chair with armrests**

p. 27 / p. 56



**Armchair**

p. 27 / p. 56



**Low bar chair**

p. 28 / p. 57



**High bar chair**

p. 28 / p. 57



**Coffee table**

p. 30 / p. 58



**Dining table**

p. 30 / p. 58



**Coffee table**

p. 33 / p. 58



**Dining table**

p. 33 / p. 59



**Side table**

p. 34 / p. 59



**High side table**

p. 34 / p. 59

## Milane collection

---



**Chair**

p. 42 / p. 60



**Chair with armrests**

p. 42 / p. 60



**Armchair**

p. 42 / p. 60



**Side table & Stool**

p. 45 / p. 61

## Lottie collection

---



**Side table & Stool**

p. 51 / p. 62



**Coffee table**

p. 51 / p. 62



**Dining table**

p. 51 / p. 62

## Premo collection

---



**Chair with armrests**

p. 53 / p. 63



**Chair with armrests**

p. 53 / p. 63



**Chair with armrests**

p. 53 / p. 63

## Logistics data

---

p. 54 / p. 63

# Brene



The BRENE collection is inspired by the timeless and iconic bentwood furniture.  
In the photo: a chair with armrests, a side table, an armchair, and a chair.

# FERNE

FERNE



## Timeless and light beauty.

The BRENE collection redefines design. It has been inspired by the timeless and iconic bentwood furniture which was manufactured in the region of Bielsko-Biala in the early 20th century. The projects are marked by visual lightness and elegance, which match both modern and classic spaces. The cohesive colour palette has been carefully designed to create one-of-a-kind arrangements by freely combining pieces in different colours. All of the above makes the BRENE collection perfect for versatile uses.

When designing the furniture, we placed emphasis on human-oriented ergonomics, with the users' needs in mind. The seats and backrests are made of breathable slats and they adapt naturally to the body shape for ultimate comfort. All the items in the collection are lightweight and easy to carry. Their construction prevents water pooling, so they are hard-wearing and easy to clean as well. With its top-notch quality, durability, and timeless design, the BRENE collection is made to last. What's more, particular pieces can be stacked, which makes their storage extremely convenient. All these features mean that every element of the BRENE collection is a synonym for elegance, corresponding with the needs of the most demanding design lovers. The collection consists of a coffee table, an side table, a dining table, a chair, a chair with armrests, and an armchair.



The lightweight construction of BRENE collection makes all items easy to move and store.  
In the photo: BRENE armchairs.  
Above: armchairs with a side table.

have a seat.



# FERNE



The seats and backrests of BRENE are made of breathable slats and they adapt naturally to the body shape for ultimate comfort.



Chair

FBRK558

520 x 530 x 825



Chair with armrests

FBRK658

575 x 530 x 825



Armchair

FBRK767

670 x 625 x 740

**must  
have**

# Brene

The seating options that form the BRENE collection are exceptionally practical and comfortable.

The triangular slats ensure airiness and comfort of sitting. The lightweight construction of the chairs makes them easy to move and store. All the BRENE chairs are moisture-resistant and can be stacked.

They are a perfect choice for both outdoors and indoors — they will work well in any conditions that require durability and resistance.

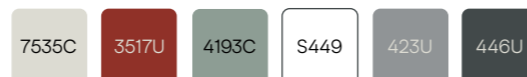

have a seat.



Side table

FBR554

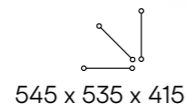

Coffee table

FBR884

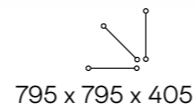

Dining table

FBR888

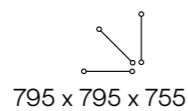

**must  
have**

# Brene

The dining tables, coffee tables, and side tables by BRENE will help you arrange the space in a comprehensive way.

Thanks to the use of slats, the tables are light and easy to keep clean, while remaining robust and durable. As they can be easily stacked, the collection is a convenient choice wherever storage and frequent rearrangements are of importance.

The legs for the dining table and the coffee table are packed separately and they are very easy to assemble. Transporting furniture in parts is a great way to reduce carbon foot print and improve the overall logistics.

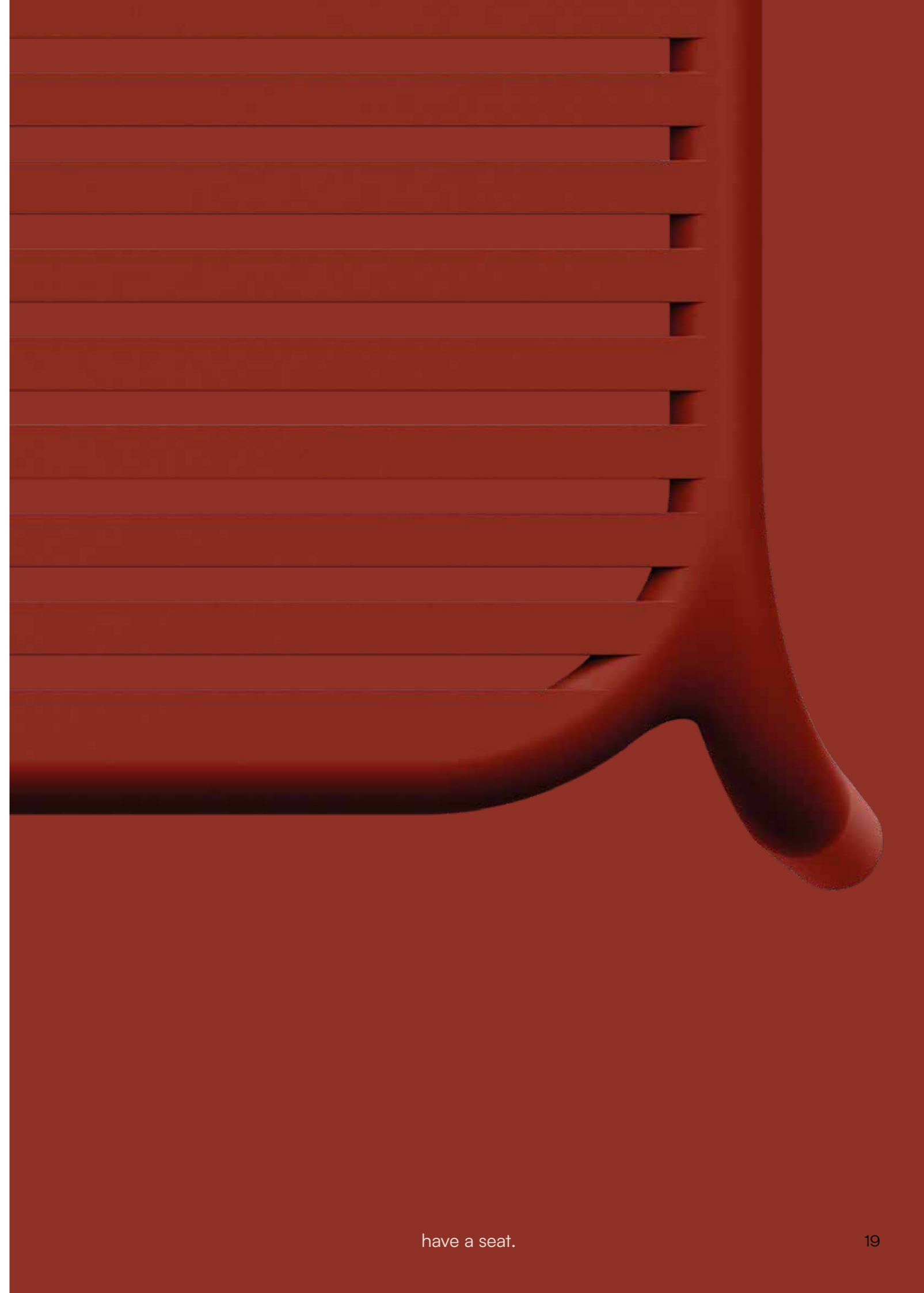
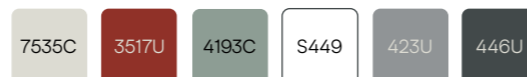

# Rimo



The RIMO collection combines the classic elegance with modern materials and functionality.  
In the photo: an armchair, a low bar chair, and a chair with armrests.

# FERNE

FERNE



## Light classic collection.

The RIMO collection combines the elegance of classic bentwood furniture with modern design and functionality. Here, tradition meets innovation, and the classic form is paired with modern moulding methods and materials. The gentle rounded shapes that allude to Thonet's designs are coupled with stylish colours to give the furniture a delicate and fashionable look.

The smooth lines and "bent" elements create a harmonious combination of classic design and modern solutions. Made with precision and attention to detail, the collection is of prime quality. The RIMO furniture is functional and comfortable while retaining timeless aesthetics. It's a sustainable and affordable alternative to traditional wooden chairs.

The collection comprises a chair, a chair with armrests, an armchair, two bar chairs of different heights, a round side table, a round high side table, coffee tables, and dining tables.



In the photo: An armchair and a low bar chair from the RIMO collection.  
Above: a high side table.



have a seat.



The RIMO furniture is functional and comfortable while retaining timeless aesthetics.  
In the photo: armchairs with a side table.



Chair

FRIK568

475 x 555 x 840



Chair with armrests

FRIK658

570 x 555 x 840



Armchair

FRIK667

620 x 625 x 748

# Rimo

The chairs from the RIMO collection are an example of a harmonious match between classic design and modern functionality.

The designers focused equally on how the chairs look and how comfortable they should be. This resulted in an original system of testing the ergonomics of the chairs and optimising their weight.

What's more, as the chairs are stackable, they can be easily rearranged and stored. Comfort and stability are ensured by the rubber chair feet.

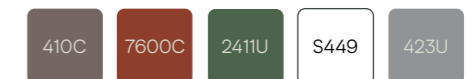

structure effect

FERNE



Low bar chair

FRIK5510

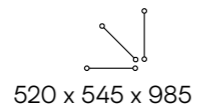

High bar chair

FRIK5511

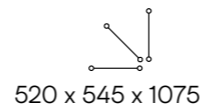

# Rimo

The bar chairs by RIMO manifest the elegance of classic design and high production quality.

They come in two heights. Their gentle shapes and delicate lines as well as light construction and refined details make them an ideal element of outdoor and indoor decors.

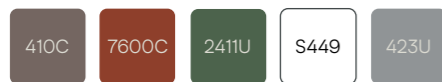

structure effect







Coffee table

FRIS884

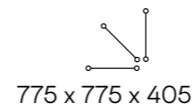

775 x 775 x 405



Dining table

FRIS887

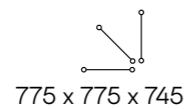

775 x 775 x 745

# Rimo

The square tables by RIMO are perfect for homes and gardens. They are robust, elegant, and made with care. A table like this is not only a practical piece of furniture but also an eye-pleasing touch to any kind of space. Thanks to their universal design and weather resistance, the tables will find their place on a terrace or in a garden. They bring functional elegance to every spot.

The legs for the dining table and the coffee table are packed separately and they are very easy to assemble. Transporting furniture in parts is a great way to reduce carbon foot print and improve the overall logistics.



structure effect





Dining table

FRIS867

775 x 575 x 745



Coffee table

FRIS864

775 x 575 x 405

# Rimo

The rectangular tables by RIMO are perfect for homes and gardens. They are robust, elegant, and made with care. A table like this is not only a practical piece of furniture but also an eye-pleasing touch to any kind of space. Thanks to their universal design and weather resistance, the tables will find their place on a terrace or in a garden. They bring functional elegance to every spot.

The legs for the dining table and the coffee table are packed separately and they are very easy to assemble. Transporting furniture in parts is a great way to reduce carbon footprint and improve the overall logistics.



structure effect



Side table

FRIS64

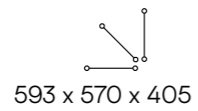

593 x 570 x 405

# Rimo

The round tables by RIMO are a perfect match for gardens and home interiors, cafes, and leisure spaces. With their elegant design, solid construction, and universal nature, the tables are a great addition to any arrangement.

The legs are packed separately and they are very easy to assemble. Transporting furniture in parts is a great way to reduce carbon foot print and improve the overall logistics.

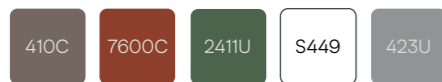

structure effect



High side table

FRIS67

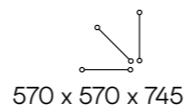

570 x 570 x 745



# Milane



Characteristics of the MILANE collection include the minimalist style,  
exceptional sitting comfort, and a simple logistics.  
In the photo: a chair with armrests, an armchair, and a chair.

# FERNE



# Available comfort.

MILANE is an impressive collection of comfortable garden furniture. Its characteristics include the minimalist style, exceptional sitting comfort, and simple logistics. As monolithic forms are very popular among users, we have decided to create an entire collection in this spirit. By optimising the production process, we've made sure the collection is affordable for the wide public.

With their distinctive bends and soft shapes, all the pieces look strong and attractive, ensuring stability and durability. The single-point injection technology used in the MILANE collection created the smooth shapes of the furniture, emphasised by the satin finishing. The collection offers an array of subtle, timeless colours. MILANE comprises a chair, a chair with armrests, an armchair, and an side table that can also serve as a stool.



In the photos: a MILANE armchair.

have a seat.

# FERNE



The side table from MILANE collection is elegant and multifunctional:  
it can be used as a stool, or a footrest.



have a seat.



Chair

FMIK667

  
580 x 600 x 735



Chair with armrests

FMIK768

  
680 x 600 x 805



Armchair

FMIK777

  
745 x 730 x 735

# Milane

The chairs and armchairs by MILANE are lightweight and easy to move, store, and clean.

This makes them functional, practical, and widely available. What's more, the chairs can be easily stacked on top of one another.





# Milane

The low side table from the MILANE collection is a great addition to every garden and leisure space. It's elegant and multifunctional: it can be used as a table, a stool, or a footrest.

Side table & Stool

FMIS554

485 x 485 x 420





# Lottie



LOTTIE is a family of essential, stylish and functional garden tables.  
In the photo: a side table, a dining table, and a coffee table.

# FERNE



# Essential garden table.

LOTTIE is a family of stylish and functional outdoor tables that will be a great fit for every type of garden or leisure space. The tables are very easy to clean, use, and store.

The family comprises a dining table, a coffee table, and a side table, which can be used as a stool. The LOTTIE products are available in basic colours, so they can be easily matched with all the other FERNE items.



have a seat.



Side table & Stool

FLOS445

396 x 396 x 465



Dining table

FLOS888

775 x 775 x 765



Coffee table

FLOS866

770 x 590 x 565

# Lottie

The tables are very easy to clean, use, and store. The collection comprises a high table, a coffee table, and a side table, which can be used as a stool.





Chair with armrests

FPRK568

560 x 590 x 810



Chair with armrests

FPRK758

650 x 560 x 825



Chair with armrests

FPRK658

615 x 560 x 815

# Premo

PREMO is a modern interpretation of a classic garden chair. The product comes in three variants. It's perfect for places where quick rearrangements happen on a daily basis: the chairs can be easily moved in, out, and around, and they are convenient to store.

The PREMO chair is an attractive and functional solution for every balcony, garden, and stylish cafe. It has been carefully designed also in terms of colour and form.





**Brene**  
FBRK558

symbol:	dimensions (mm): length /width /height	maximum weight:	packaging (pcs):	pallet height:	stackable:
	520 x 530 x 825	110	24	~ 1700	✓



**Brene**  
FBR554

symbol:	dimensions (mm): length /width /height	maximum weight:	packaging (pcs):	pallet height:	stackable:
	545 x 535 x 415	50	24	~ 950	✓



**Brene**  
FBRK658

symbol:	dimensions (mm): length /width /height	maximum weight:	packaging (pcs):	pallet height:	stackable:
	575 x 530 x 825	110	24	~ 1700	✓

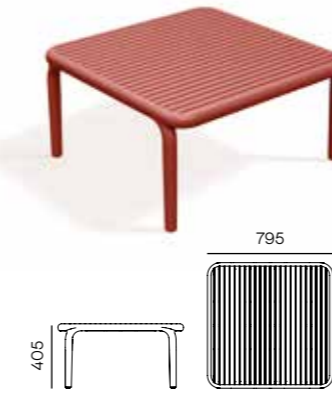

**Brene**  
FBR5884

symbol:	dimensions (mm): length /width /height	maximum weight:	packaging (pcs):	pallet height:	stackable:
	795 x 795 x 405	100	12	~ 1805	✓



**Brene**  
FBRK767

symbol:	dimensions (mm): length /width /height	maximum weight:	packaging (pcs):	pallet height:	stackable:
	670 x 625 x 740	110	14	~ 1670	✓



**Brene**  
FBR5888

symbol:	dimensions (mm): length /width /height	maximum weight:	packaging (pcs):	pallet height:	stackable:
	795 x 795 x 765	100	12	~ 1805	✓



structure effect

**Rimo**

FRIK568

symbol:

dimensions (mm): length /width /height  
475 x 555 x 840

maximum weight:  
110

packaging (pcs):  
20

pallet height:  
~ 1700

stackable:  
✓

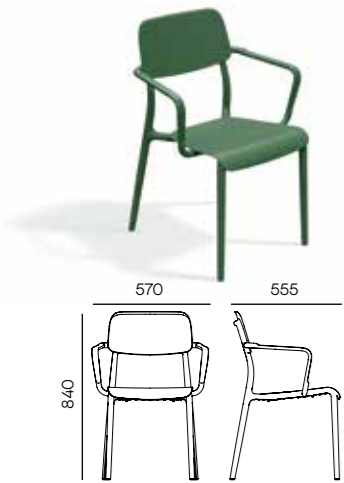

structure effect

**Rimo**

FRIK658

symbol:

dimensions (mm): length /width /height  
570 x 555 x 840

maximum weight:  
110

packaging (pcs):  
16

pallet height:  
~ 1740

stackable:  
✓

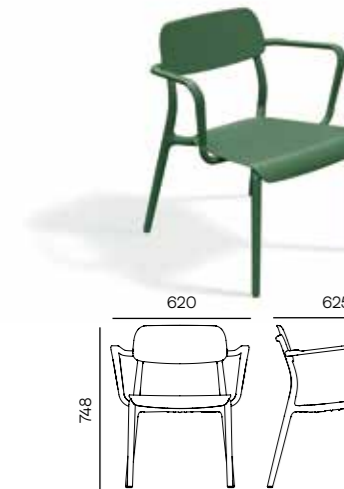

structure effect

**Rimo**

FRIK667

symbol:

dimensions (mm): length /width /height  
620 x 625 x 748

maximum weight:  
110

packaging (pcs):  
-

pallet height:  
~ -

stackable:  
✓



structure effect

**Rimo**

FRIK551

symbol:

dimensions (mm): length /width /height  
520 x 545 x 985

maximum weight:  
110

packaging (pcs):  
12

pallet height:  
~ 1660

stackable:  
✓



structure effect

**Rimo**

FRIK511

symbol:

dimensions (mm): length /width /height  
520 x 545 x 1075

maximum weight:  
110

packaging (pcs):  
8

pallet height:  
~ 1350

stackable:  
✓





earthy toupe  
410C



burnt brick  
7600C



pine green  
2411U

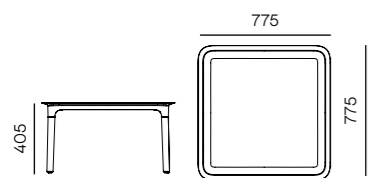

white  
S449



agate gray  
423U



structure effect

### Rimo

FRIS884

symbol:

dimensions (mm): length /width /height

775 x 775 x 405

maximum weight:

100

packaging (pcs):

26

pallet height:

~ 1910

stackable:

✓



earthy toupe  
410C



burnt brick  
7600C



pine green  
2411U

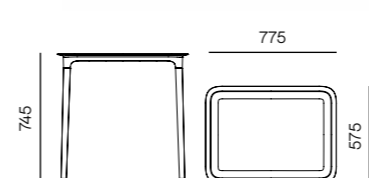

white  
S449



agate gray  
423U



structure effect

### Rimo

FRIS867

symbol:

dimensions (mm): length /width /height

775 x 575 x 745

maximum weight:

100

packaging (pcs):

36

pallet height:

~ 1915

stackable:

✓



earthy toupe  
410C



burnt brick  
7600C



pine green  
2411U

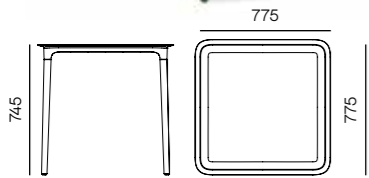

white  
S449



agate gray  
423U



structure effect

### Rimo

FRIS887

symbol:

dimensions (mm): length /width /height

775 x 775 x 745

maximum weight:

100

packaging (pcs):

26

pallet height:

~ 1910

stackable:

✓



earthy toupe  
410C



burnt brick  
7600C



pine green  
2411U

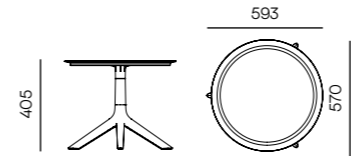

white  
S449



agate gray  
423U



structure effect

### Rimo

FRIS64

symbol:

dimensions (mm): length /width /height

593 x 570 x 405

maximum weight:

100

packaging (pcs):

30

pallet height:

~ 1950

stackable:

✓



earthy toupe  
410C



burnt brick  
7600C



pine green  
2411U

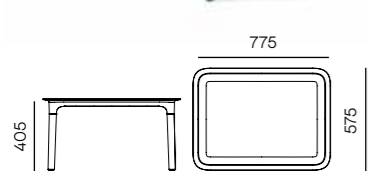

white  
S449



agate gray  
423U



structure effect

### Rimo

FRIS864

symbol:

dimensions (mm): length /width /height

775 x 575 x 405

maximum weight:

100

packaging (pcs):

36

pallet height:

~ 1915

stackable:

✓



earthy toupe  
410C



burnt brick  
7600C



pine green  
2411U



white  
S449



agate gray  
423U



structure effect

### Rimo

FRIS67

symbol:

dimensions (mm): length /width /height

570 x 570 x 745

maximum weight:

100

packaging (pcs):

30

pallet height:

~ 1950

stackable:

✓



<b>Milane</b>	symbol:	dimensions (mm): length /width /height	maximum weight:	packaging (pcs):	pallet height:	stackable:
	FMIK667	580 x 600 x 735	110	32	~ 1830	✓



<b>Milane</b>	symbol:	dimensions (mm): length /width /height	maximum weight:	packaging (pcs):	pallet height:	stackable:
	FMIS554	485 x 485 x 420	50	64	~ 1900	✓



<b>Milane</b>	symbol:	dimensions (mm): length /width /height	maximum weight:	packaging (pcs):	pallet height:	stackable:
	FMIK768	680 x 600 x 805	110	32	~ 1830	✓



<b>Milane</b>	symbol:	dimensions (mm): length /width /height	maximum weight:	packaging (pcs):	pallet height:	stackable:
	FMIK777	745 x 730 x 735	110	18	~ 1830	✓





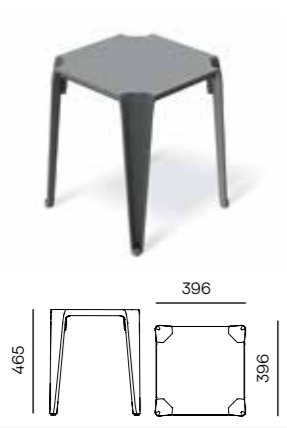

	senza 7535C		verde 4193C		light gray 443U
	basalt 433C				

<b>Lottie</b>	symbol:	dimensions (mm): length /width /height	maximum weight:	packaging (pcs):	pallet height:	stackable:
	FLOS445	396 x 396 x 465	50	90	~ 1900	✓

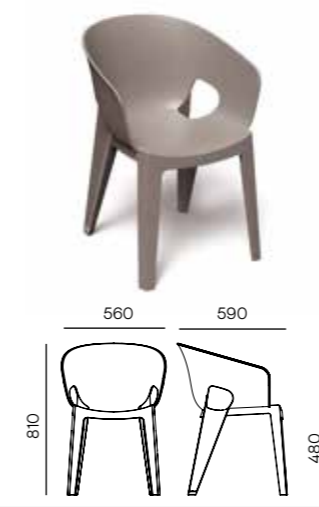

	senza 7535C		earthy toupe 410C		verde 4193C
	light gray 443U		basalt 433C		

<b>Premo</b>	symbol:	dimensions (mm): length /width /height	maximum weight:	packaging (pcs):	pallet height:	stackable:
	FPRK568	560 x 590 x 810	110	-	~ -	✓

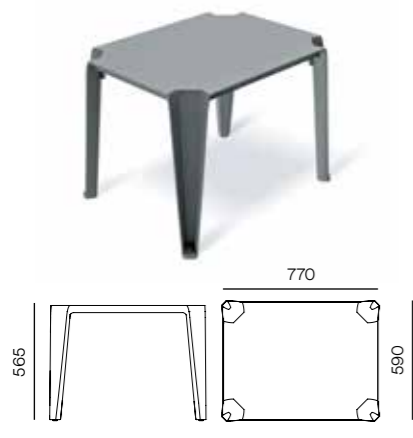

	senza 7535C		verde 4193C		light gray 443U
	basalt 433C				

<b>Lottie</b>	symbol:	dimensions (mm): length /width /height	maximum weight:	packaging (pcs):	pallet height:	stackable:
	FLOS866	770 x 590 x 565	100	30	~ 1850	✓

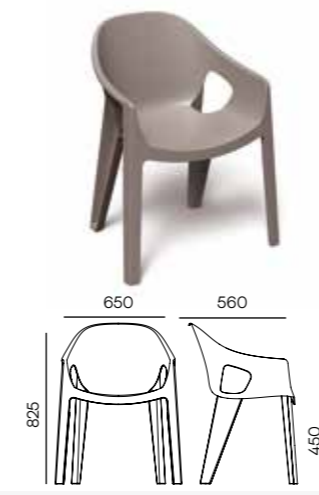

	senza 7535C		earthy toupe 410C		verde 4193C
	light gray 443U		basalt 433C		

<b>Premo</b>	symbol:	dimensions (mm): length /width /height	maximum weight:	packaging (pcs):	pallet height:	stackable:
	FPRK758	650 x 560 x 825	110	-	~ -	✓



	senza 7535C		verde 4193C		light gray 443U
	basalt 433C				

<b>Lottie</b>	symbol:	dimensions (mm): length /width /height	maximum weight:	packaging (pcs):	pallet height:	stackable:
	FLOS888	775 x 775 x 765	100	12	~ 1900	✓

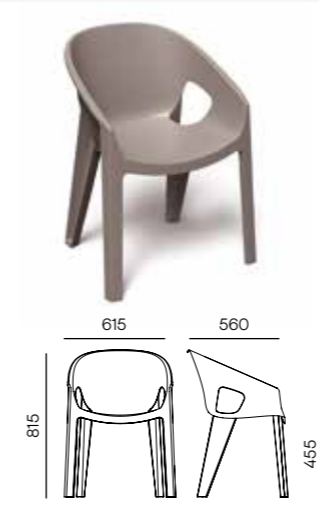

	senza 7535C		earthy toupe 410C		verde 4193C
	light gray 443U		basalt 433C		

<b>Premo</b>	symbol:	dimensions (mm): length /width /height	maximum weight:	packaging (pcs):	pallet height:	stackable:
	FPRK658	615 x 560 x 815	110	-	~ -	✓

over 90 countries worldwide

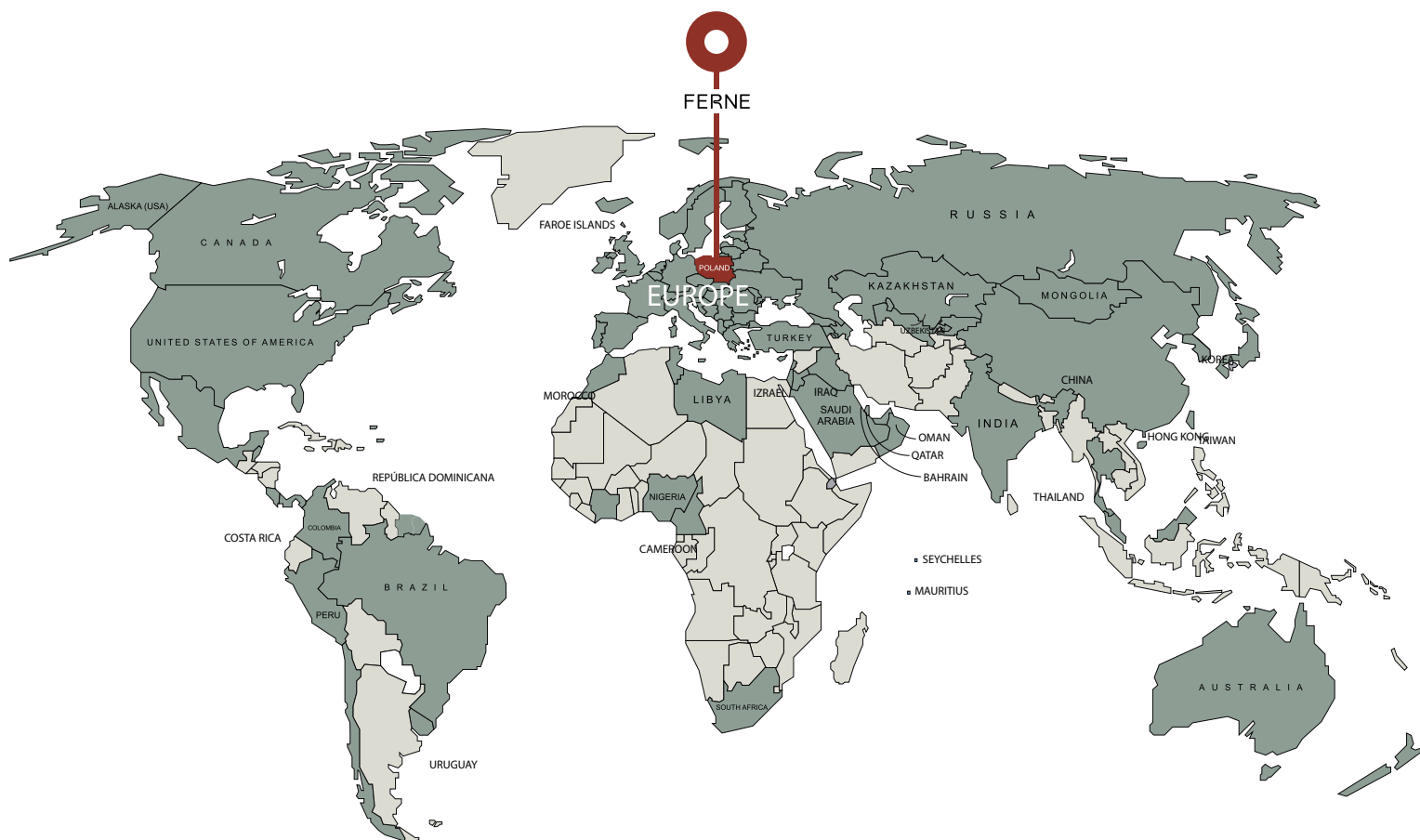

Constantly launching an innovative, diversified and high quality products and being a reliable partner, we managed to succeed on the market in different parts of the world.

Currently our products are successfully distributed to more than 90 countries worldwide and the number of satisfied customers is increasing each year!

## Contact us

### Poland

#### Headquarter, Production & Warehouse

Prosperplast 1 Sp. z o. o.  
Wilkowska 968  
43-378 Rybarzowice  
Poland

tel. +48 33 817 70 03  
fax +48 33 817 60 81

biuro@prosperplast.pl  
office@prosperplast.pl  
www.prosperplast.pl

### Germany

#### Office

Prosperplast Deutschland GmbH  
Hopfenstraße 22a  
85283 Wolnzach  
Germany

tel. +49 8442 9628499  
fax +49 8442 9680853

kontakt@prosperplast.de  
www.prosperplast.de

### Czechia

#### Office & Warehouse

Prosperplast s.r.o.  
CTPark Ostrava Hrušov  
Bohumínská 710/198  
711 00 Slezská Ostrava - Hrušov  
Czech Republic

tel. +420 553 034 443  
mob +420 605 499 544

info@prosperplast.cz  
www.prosperplast.cz

### Hungary

#### Office

Prosperplast Kft.  
Tátra u. 5/a, alagsor 2.  
1136-H Budapest,  
Hungary

tel. +36 30 4095 120  
mob +36 30 4095 710

office@prosperplast.hu  
www.prosperplast.hu

Wszystkie prawa zastrzeżone przez Prosperplast 1 Spółka z o.o., a zawartość nie może być powielana, pobierana, rozpowszechniana, publikowana lub przekazywana w jakiegokolwiek formie i w jakikolwiek sposób, bez uprzedniej pisemnej zgody Prosperplast 1 Spółka z o.o.  
Niniejszy katalog nie stanowi oferty w rozumieniu obowiązujących przepisów. Za błędy w druku nie odpowiadamy.

All rights are reserved by Prosperplast 1 Spółka z o. o. and content may not be reproduced, downloaded, disseminated, published, or transferred in any form or by any means, except with the prior written permission of Prosperplast 1 Spółka z o.o.

This catalogue does not constitute an offer within the meaning of applicable rules. We are not responsible for printing errors.

# FERNE

ferne.pl

Prosperplast 1 Sp. z o.o.  
Wilkowska 968  
43-378 Rybarzowice  
Poland